

WIND FORECASTING USING ARTIFICIAL NEURAL NETWORKS: A SURVEY AND TAXONOMY

Arpita Yadav¹, Kapil Sahu²

M.Tech Scholar, Deptt CSE., SIMS, Durg

Asst. Professor, Dept CSE, SIMS, Durg

arpitayadav11@gmail.com

kapil.sahu@sims-indore.com

Abstract

Artificial Intelligence is a domain of computer science which is finding its applications in almost all domains of science and technology. Due to plummeting non-renewable reserve of resources to produce electricity, renewable resources are being considered very seriously. One such paradigm is wind power which is based on wind speed. Previously statistical models were used for the prediction of wind speed and hence wind power, but with the advent of Artificial Neural Networks, wind speed forecasting using Artificial Neural Networks has become an active area of research. The present paper introduces the need of wind speed prediction and subsequently the use of Artificial Neural Networks for the same. Different ANN architectures and their properties are presented here for a clear understanding of the tools being used. Finally evaluation parameters are discussed which evaluate the performance of any proposed system.

Keywords:- Wind Speed, Artificial Neural Network (ANN), ANFS- Adaptive Neuro-Fuzzy System

I. INTRODUCTION

In recent years, the requirement for energy has been continuously increasing. Utilizing renewable energy resources is a high priority within energy production and management policies in many countries.[1] The growing rate of demand for energy and the global warming phenomenon, which has raised a lot of concern about carbon dioxide emissions along with the high price of fossil fuel, has led governments to consider the utilization of new sources of energy. Several nuclear power-plant disasters and their long-term effects on the next generations' health and environment have also initiated a series of debates on eliminating nuclear power from the future energy policies for some countries. Wind is a free and easily available source of energy and appears to be the fastest growing of renewable energy resources. Wind power system penetration to the existing power system possess problems as running problems (frequency, power balance, voltage support, and quality of power), planning and economic problems (including uncertainty in wind power in to unit commitment, economic load scheduling, and spinning reserve calculations), etc.

Previously statistical models were used for the prediction of wind speed and thereby wind power, but it lacked accuracy due to its inability to follow complex wind speed patterns accurately. Thus the focus started shifting on Artificial Intelligence tools to forecast wind speed. The subsequent sections introduce the basics of artificial neural network, its functioning and various architectures of artificial neural networks.

II. ARTIFICIAL NEURAL NETWORK (ANN)

Work on artificial neural network has been motivated right from its inception by the recognition that the human brain computes in an entirely different way from the conventional digital computer.[5],[7] The brain is a highly complex, nonlinear and parallel information processing system. It has the capability to organize its structural constituents, known as neurons, so as to perform certain computations many times faster than the fastest digital computer in existence today. The brain routinely accomplishes perceptual recognition tasks, e.g. recognizing a familiar face embedded in an unfamiliar scene, in approximately 100-200 ms, whereas tasks of much lesser complexity may take days on a conventional computer. A neural network is a machine that is designed to model the way in which the brain performs a particular task. The network is implemented by using electronic components or is simulated in software on a digital computer. A neural network is a massively parallel distributed processor made up of simple processing units, which has a natural propensity for storing experimental knowledge and making it available for use. It resembles the brain in two respects:

1. Knowledge is acquired by the network from its environment through a learning process.
2. Interneuron connection strengths, known as synaptic weights, are used to store the acquired knowledge.

Neural networks, with their remarkable ability to derive meaning from complicated or imprecise data, can be used to extract patterns and detect trends that are too complex to be noticed by either humans or other computer techniques. Other advantages include:

1. **Adaptive learning:** An ability to learn how to do tasks based on the data given for training or initial experience.
2. **Self-Organization:** An ANN can create its own organization or representation of the information it receives during learning time.
3. **Real Time Operation:** ANN computations may be carried out in parallel, and special hardware devices are being designed and manufactured which take advantage of this capability.

The biological model of the neuron is shown in the figure. It consists of the cell body, axon hillock, action potential, synaptic terminal, axon of pre synaptic neuron and dendrites. Signals from different parts of the body travel through different parts and reach the neuron where the neuron processes it and produces an output. It should be noted though that the output of a neuron may also be fed to another neuron. A collection of such neurons is called a neural network. The neural network can perform simple to complex tasks depending on the structure of the neural network.

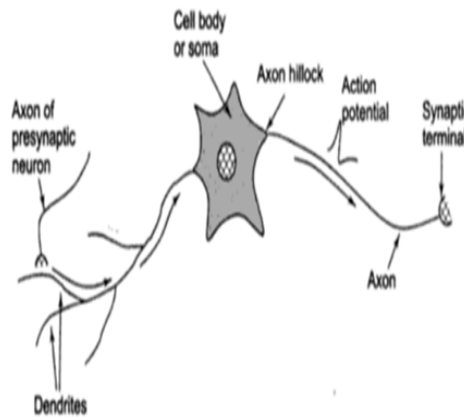

Fig.1 Biological model of neuron

After studying the basic biological model of the neural network, a mathematical model is envisaged to be designated. The mathematical model for such a neural network is given by:

$$\sum_{i=1}^n X_i W_i + \Theta$$

Where X_i represents the signals arriving through various paths, W_i represents the weight corresponding to the various paths and Θ is the bias. The above diagram exhibits the derived mathematical model of the neural network. It can be seen that various signals traversing different paths have been assigned names X and each path has been assigned a weight W . The signal traversing a particular path gets multiplied by a corresponding weight W and finally the overall summation of the signals multiplied by the corresponding path weights reaches the neuron which reacts to it according to the bias Θ . Finally its the bias that decides the activation function that is responsible for the decision taken upon by the neural network.

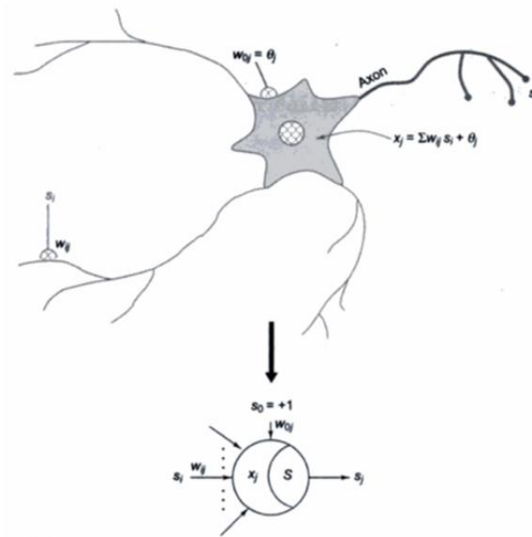

Fig.2 Mathematical model of a neural network

Neural networks can be used for tracking complex patterns in wind speed and subsequently predicting wind speed.

III. Different ANN Architectures

There are various ANN architectures which can be used for the prediction of data. The most commonly used ones are discussed below.

1. Single Layer Feed-Forward Network

In a layered neural network the neurons are organized in the form of layers. In the simplest form of a layered network, we have an input layer of source nodes that projects onto an output layer of neurons, but not vice versa. This network is strictly a feed forward type. In single-layer network, there is only one input and one output layer

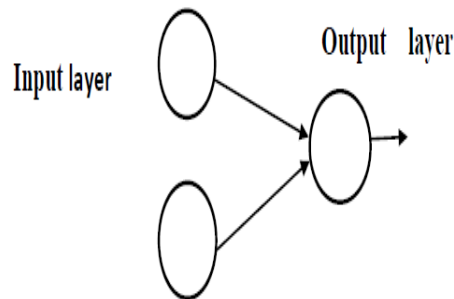

Fig.3 Single Layer Feed Forward Network

In feed forward networks, its important to note that the flow of signal is from input nodes towards the output node but the signal cannot propagate backward from the output node towards the input layers i.e feed back is not permissible.

2. Back-propagation Network (BPN)

BPN is a feed-forward network with three layers, namely input layer, hidden layer, and output layer, as shown in The number of hidden layers can be more than one, depending on the complexity of the problem. In our study, we used one hidden layer to minimize the computational time and reduce complexity of training.

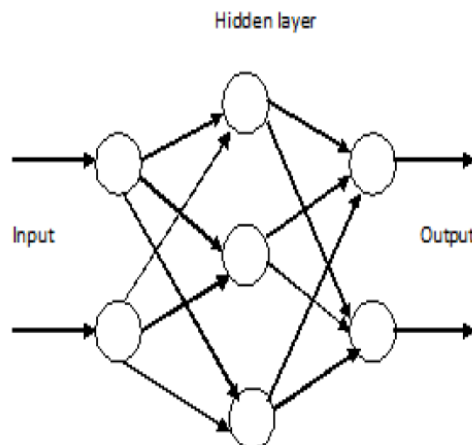

Fig.4 Architecture of Neural Network with Hidden Layers

Determining the number of layers and the number of processing elements per layer are important decisions, which are made by the programmer while creating and training the network. Training inputs are applied to the input layer of the network, and the desired outputs are compared at the output layer. The difference between the output of the final layer and the desired output is back-propagated to the previous layer(s). The back-propagated signals are usually modified by the derivative of the transfer function and the connection weights, which are usually adjusted using the Delta Rule. The minimum mean square error between the actual output layer of the network and the desired output is minimized using the gradient descent algorithm. The performance of a neural network depends on the weights and the transfer function (input-output function) specified for the units.[8]

3. Radial Basis Function Network (RBF)

It is a three-layer network, namely the input, the output and the hidden layer, where each hidden unit in a hidden layer implements a radial activated function. The main advantages of RBF's over feed-forward networks are its accuracy and shorter computational time. As Venkatesan and Anitha [16] explained, the response of the j th-hidden unit can be mathematically expressed as

$$z_j = \phi \left[\left| \frac{x - \mu_j}{\sigma_j} \right| \right]$$

where ϕ is a strictly positive, radially symmetrical function (kernel) with a unique maxima at its center, μ_j , and σ_j is the width of the receptive field. The error between the target and the desired output is minimized using gradient descent algorithm.[18]

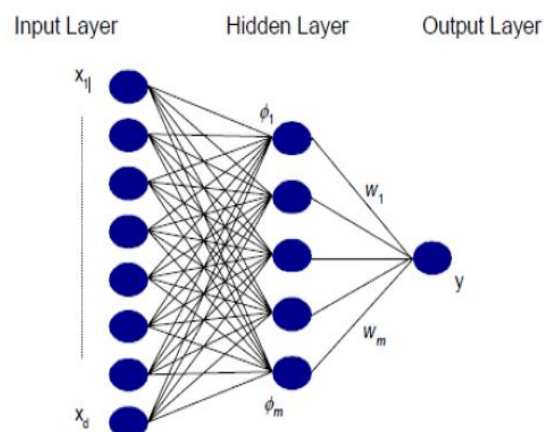

Fig5. RBF Network Architecture.

4. Adaptive neuro-fuzzy inference system (ANFIS)

Fuzzy logic and ANN are modelling methods used influentially and effectively in the problems of engineering. The modelling of fuzzy logic method is a rule-based method using the feature of human thinking and decision making. On the other hand, ANN learns the

problem by using its ability of learning and comes through successfully for data sets it did not come across before. The method of ANFIS was suggested by Jang [7] considering these advantages of ANN and fuzzy logic methods. ANFIS is an integrated form of ANN and fuzzy inference systems. The membership degree of input/output variables is determined in an ANFIS by the use of ANN's ability of learning. A conclusion is reached with the feature of reasoning and decision making of fuzzy logic method.[9]

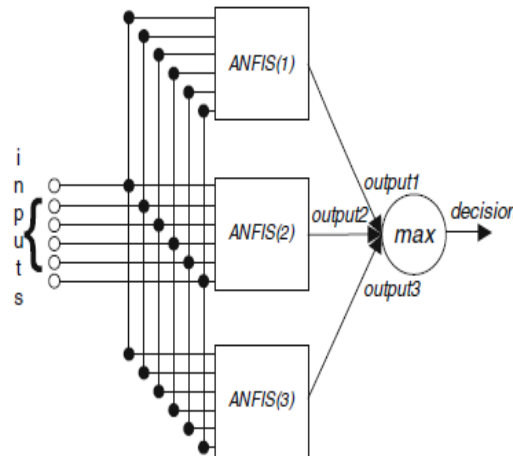

Fig5. The ANFIS Architecture

IV. Activation Functions

The activation function could be chosen from the following list: logistic sigmoid function, hyperbolic tangent function, or linear function. It is also possible to create a hybrid artificial neural network with different activation functions in different layers. However, there should be at least one non-linear activation function used in an ANN structure in order to retain its ability to solve non-linear problems.

Activation functions tell us about the type of decision the neural network takes. Based on the type of decision the neural network has to take, a mathematical function called the activation function needs to be designed.

The most commonly used activation-function features are shown in Table.1

Table.1

Activation Function	Mathematical Equation	Graphical Representation
Linear	$f(x) = x$	
Logistic sigmoidal	$f(x) = \frac{1}{(1 + e^{-x})}$	
Hyperbolic tangent	$f(x) = \frac{1 - e^{-2x}}{1 + e^{2x}}$	

Fig6. Different Activation Functions

It was shown that the activation function plays a very important role in the accuracy of artificial neural network results, but if a network could be trained successfully with a particular activation function, it would be highly probable that other activation functions would also result in an acceptable training. Linear activation functions have been used by some investigators in input and output layers. For the hidden and output layers, non-linear activation functions are used. Some studies show that the linear activation function in the output layer combined with a nonlinear activation function for a single hidden layer has positive effects on the performance of the ANN. This work adopts that ANN structure.

V. EVALUATION PARAMETERS

Since errors can be both negative and positive in polarity, therefore its immaterial to consider errors with signs which may lead to cancellation and hence inaccurate evaluation of errors. Therefore we consider mean square error and mean absolute percentage errors for evaluation. Mean Square Error is defined as:

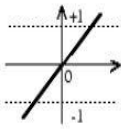
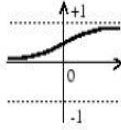
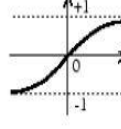
$$MSE = [\sum_{i=1}^n (X - X')^2] / n$$

Mean Absolute Percentage Error is defined as:

$$MAPE = [\sum_{i=1}^n (X - X') / X'] / n \times 100\%$$

Here, X is the predicted value and X' is the actual value and n is the number of samples.

VI. CONCLUSION:

It can be concluded form the above discussions that Artificial Neural Networks can be effectively used for wind speed prediction even though wind speed may exhibit complex time series behaviour. Various Neural Network Architectures have been discussed with their

salient features. Finally the evaluation parameters used for the evaluation of any prediction model to be designed have been explained with their physical significance and need.

REFERENCES

- [1] Tarlochan Kaur, Sanjay Kumar, Ravi Segal, “Application of Artificial Neural Network for Short Term Wind Speed Forecasting”. 2016 Biennial International Conference on Power and Energy Systems:Towards Sustainable Energy (PESTSE), 2016.
- [2] Rohan Singh, Kishan Bhushan Sahay, Shubhankar Aseet Srivastava, “Short-Term Wind Speed Forecasting of Oak Park Weather Station by Using Different ANN Algorithms”, *Innovative Smart Grid Technologies - Asia (ISGT ASIA)*, IEEE, 2015
- [3] P. Ramasamy, S.S. Chandel, Amit Kumar Yadav, “Wind speed prediction in the mountainous region of India using an artificial neural network model”, *Renewable Energy* 80, Elsevier, pp. 338-347, 2015.
- [4] Anirudh S. Shekhawat, “Wind Power Forecasting using Artificial Neural Networks”. *International Journal of Engineering Research & Technology*, Volume 3, 2014.
- [5] Kanna Bhaskar and S.N. Singh, “AWNN - Assisted Wind Power Forecasting using Feed-Forward Neural Network”. *IEEE Transactions on Sustainable Energy*, Volume 3, pp. 306-315, 2012.
- [6] Ulas Eminoglu, “A New Model for Output Power Calculation of Variable-Speed Wind Turbine Systems”. *Intl. Conference on Optimization of Electrical & Electronic Equipment (OPTIM)*, pp. 141 – 146, 2015.
- [7] Ministry of New and Renewable energy, Government of India, “Annual Report 2015-16”, <http://mnre.gov.in>, 2016.
- [8] *Renewables 2015 Global Status Report*, 2015.
- [9] *Global Wind Report, Annual Market Update*, by Global Wind Energy Council (GWEC), 2015.
- [10] Wen-Yeau Chang, “A Literature Review of Wind Forecasting Methods”, *Journal of Power and Energy Engineering*, pp. 161-168, 2014.
- [11] X. Zhao, S.X. Wang, and T. Li, “Review of Evaluation Criteria and Main Methods of Wind Power Forecasting”. *Energy Procedia*, Volume 12, pp. 761-769, 2011.
- [12] S.S. Somam, H. Zareipour, O. Malik, and P. Mandal, “A Review of Wind Power and Wind Speed Forecasting Methods with Different Time Horizons”. *North American Power Symposium*, Arlington, pp. 26-28, 2010.